

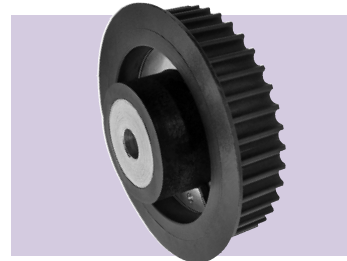

**HTD® Timing Belt Pulleys – 8 mm Pitch**

Stock Drive Products/Sterling Instrument ■ Phone: 516-328-3300 ■ Fax: 516-326-8827

- MOLDED WITH INSERT
- **TRUE METRIC®** PROFILE
- SINGLE FLANGE

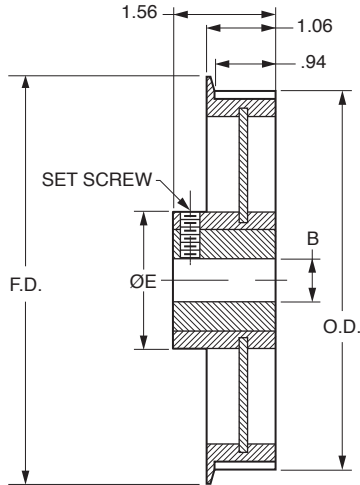

**FOR 20 mm BELTS (.787 INCH)**

**MATERIAL:** Pulley – Nylon – Black, Fiberglass Reinforced  
Insert – Aluminum

Catalog Number	No. of Grooves	P.D.	O.D. ±.005	F.D.	B Bore +.0015 +.0005	E Hub	Set Screw
A 6E28-030SF2016	30	3.008	2.954	3.35	.5000	1.50	#10-24
A 6E28-030SF2020					.6250		1/4-20
A 6E28-032SF2016	32	3.208	3.154	3.54	.5000	1.50	#10-24
A 6E28-034SF2016	34	3.409	3.355	3.82	.5000	2.00	#10-24
A 6E28-036SF2016					.5000		#10-24
A 6E28-036SF2020	36	3.609	3.555	3.93	.6250	2.00	1/4-20
A 6E28-038SF2016	38	3.810	3.756	4.13	.5000	2.00	#10-24
A 6E28-040SF2016					.5000		#10-24
A 6E28-040SF2020	40	4.010	3.956	4.33	.6250	2.00	1/4-20
A 6E28-044SF2016	44	4.411	4.357	4.77	.5000	2.00	#10-24
A 6E28-048SF2020	48	4.812	4.758	5.16	.6250	2.00	1/4-20
A 6E28-056SF2020	56	5.614	5.560	5.95	.6250	2.00	1/4-20

Other bore sizes available on special request