

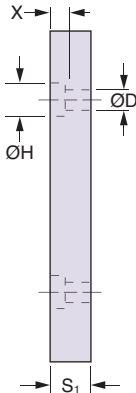

AT Timing Belt Clamp Kit – 5 mm & 10 mm Pitch

Stock Drive Products/Sterling Instrument ■ Phone: 516-328-3300 ■ Fax: 516-326-8827

■ USED IN LINEAR DRIVES

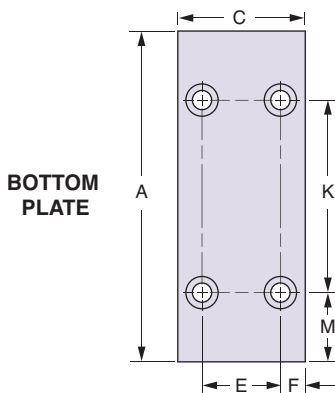
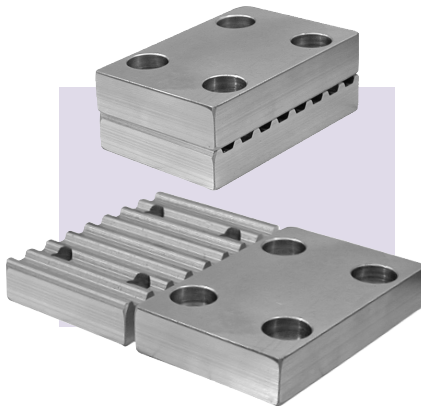
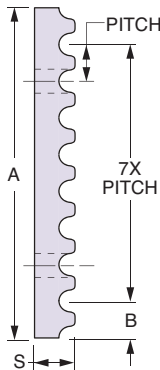
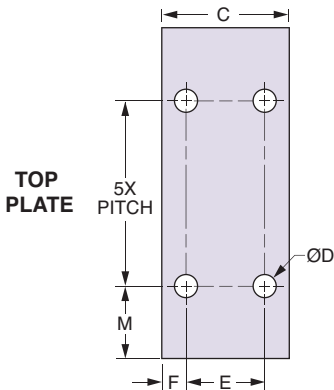

5 mm PITCH						
F mm (in.)	M mm (in.)	S mm (in.)	H mm (in.)	K mm (in.)	X mm (in.)	S ₁ mm (in.)
7.5 (.295)	9 (.354)	8 (.315)	10 (.394)	25 (.984)	5 (.197)	10 (.394)

10 mm PITCH						
F mm (in.)	M mm (in.)	S mm (in.)	H mm (in.)	K mm (in.)	X mm (in.)	S ₁ mm (in.)
10 (.394)	17.5 (.689)	15 (.591)	15 (.591)	50 (1.969)	8 (.315)	16 (.630)

Timing Belt Clamp Kit Includes:
Top and Bottom Plate and Hardware for Assembly

MATERIAL: Aluminum

Sold as Set

AT • 5 mm PITCH							Toothed + Flat Plate Total Weight (with hardware) kg (lb.)
Catalog Number	Belt Width mm (in.)	A mm (in.)	B mm (in.)	C mm (in.)	D mm (in.)	E mm (in.)	
A16A45M06	6 (.236)	43 (1.693)	4 (.157)	27.5 (1.083)	5.5 (.217)	12.5 (.492)	0.050 (.11)
A16A45M10	10 (.3937)			31.5 (1.240)		16.5 (.650)	
A16A45M16	16 (.630)			37.5 (1.476)		22.5 (.886)	
A 16A45M25	25 (.984)			46.5 (1.831)		31.5 (1.240)	

AT • 10 mm PITCH							Toothed + Flat Plate Total Weight (with hardware) kg (lb.)
Catalog Number	Belt Width mm (in.)	A mm (in.)	B mm (in.)	C mm (in.)	D mm (in.)	E mm (in.)	
A16A49M16	16 (.630)	85 (3.346)	7.5 (.295)	46.5 (1.831)	9 (.354)	26.5 (1.043)	0.313 (.69)
A16A49M25	25 (.984)			55.5 (2.185)		35.5 (1.398)	
A16A49M32	32 (1.260)			62.5 (2.461)		42.5 (1.673)	

NOTE: Hardware for kit includes screws, washers and hex nuts for assembly.
For replacement hardware kit, order: **A16A45MBOLTKIT** AT5 mm Pitch
A16A49MBOLTKIT AT10 mm Pitch