

SDPSI HTD® Timing Belt Clamp Kit – 5 mm & 8 mm Pitch

Stock Drive Products/Sterling Instrument ■ Phone: 516-328-3300 ■ Fax: 516-326-8827

■ **USED IN LINEAR DRIVES**

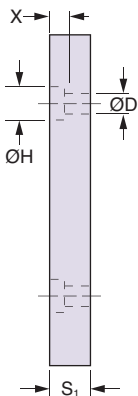
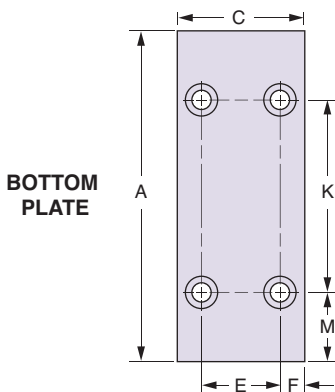
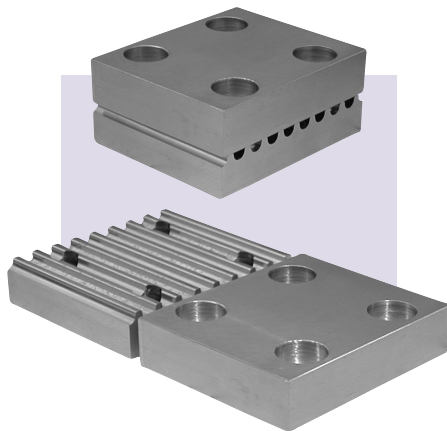
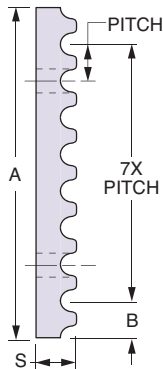
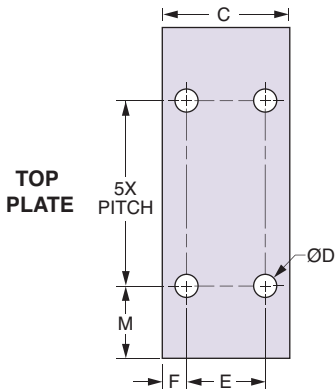

5 mm PITCH						
F mm (in.)	M mm (in.)	S mm (in.)	H mm (in.)	K mm (in.)	X mm (in.)	S ₁ mm (in.)
7.5 (.295)	10 (.394)	8 (.315)	10 (.394)	25 (.984)	5 (.197)	10 (.394)

8 mm PITCH						
F mm (in.)	M mm (in.)	S mm (in.)	H mm (in.)	K mm (in.)	X mm (in.)	S ₁ mm (in.)
10 (.394)	16 (.630)	15 (.591)	15 (.591)	40 (1.574)	8 (.315)	16 (.630)

Timing Belt Clamp Kit Includes:
Top and Bottom Plate and Hardware for Assembly

MATERIAL: Aluminum

Sold as Kit

HTD® • 5 mm PITCH							Toothed + Flat Plate Total Weight (with hardware) kg (lb.)	
Catalog Number	Belt Width mm (in.)	A mm (in.)	B mm (in.)	C mm (in.)	D mm (in.)	E mm (in.)		
A16A25M09	6 (.236) & 9 (.354)	45 (1.772)	5 (.197)	31.5 (1.24)	5.5 (.217)	16.5 (.650)	0.068 (.15)	
A16A25M15	15 (.591)			36.5 (1.44)		21.5 (.846)		0.068 (.15)
A16A25M25	25 (.984)			46.5 (1.83)		31.5 (1.24)		

HTD® • 8 mm PITCH							Toothed + Flat Plate Total Weight (with hardware) kg (lb.)	
Catalog Number	Belt Width mm (in.)	A mm (in.)	B mm (in.)	C mm (in.)	D mm (in.)	E mm (in.)		
A16A28M20	20 (.787)	72 (2.835)	8 (.315)	50.5 (1.988)	9 (.354)	30.5 (1.201)	0.272 (.60)	
A16A28M30	30 (1.181)			60.5 (2.382)		40.5 (1.594)		0.331 (.73)
A16A28M50	50 (1.969)			80.5 (3.169)		60.5 (2.382)		

NOTE: Hardware for kit includes screws, washers and hex nuts for assembly.

For replacement hardware kit, order: **A16A25MBOLTKIT** HTD®5 mm Pitch

A16A28MBOLTKIT HTD®8 mm Pitch