

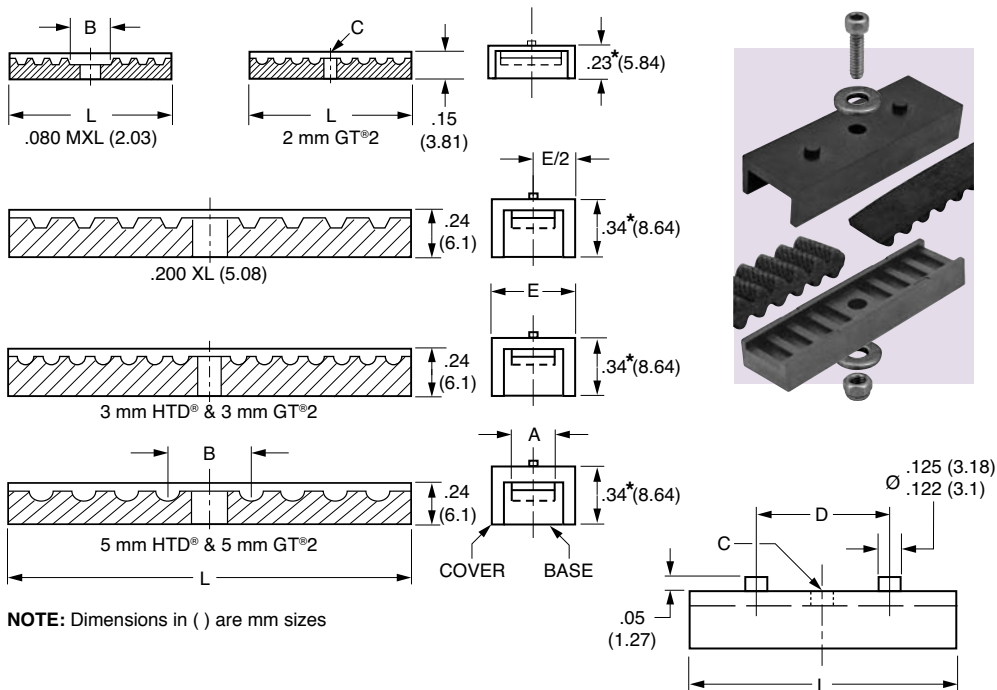

# Timing Belt Clamps

Stock Drive Products/Sterling Instrument    ■    Phone: 516-328-3300    ■    Fax: 516-326-8827

- FOR RECIPROCATING DRIVES
- COMPACT
- LOW INERTIA
- PATENT PENDING
- FOR SINGLE-AND DOUBLE-SIDED BELTS



**NOTE:** Dimensions in ( ) are mm sizes

**MATERIAL:** Base & Cover – Black Polycarbonate  
Hardware – 303 Stainless Steel

Catalog Number	Pitch	For Belt Widths		A	B	C	D	E Cover Width	L
		Inch	Metric						
A 6M16M030	MXL .080	1/8	3	.135 (3.43)	.160 (4.06)	.093 (2.36)	.500 (12.7)	.32 (8.13)	.750 (19.05)
A 6M16M045		3/16	4.5	.197 (5)		.093 (2.36)		.39 (9.91)	
A 6M16M060		1/4	6	.260 (6.6)		.125 (3.18)		.45 (11.43)	
A 6M16M080		5/16	8	.322 (8.18)		.145 (3.68)		.50 (12.7)	
A 6M16M095		3/8	9.5	.385 (9.78)		.145 (3.68)		.57 (14.48)	
A 6M 3M060	XL .200	1/4	6	.265 (6.73)	.380 (9.65)	.125 (3.18)	1.000 (25.4)	.50 (12.7)	1.880 (47.75)
A 6M 3M080		5/16	8	.327 (8.31)	.145 (3.68)	.63 (16)			
A 6M 3M095		3/8	9.5	.390 (9.91)	.145 (3.68)	.63 (16)			
A 6M51M030	GT2 (2 mm)	3	3	.130 (3.3)	.168 (4.27)	.093 (2.36)	.500 (12.7)	.32 (8.13)	.750 (19.05)
A 6M51M060		6	6	.250 (6.35)		.125 (3.18)		.45 (11.43)	
A 6M51M090		9	9	.370 (9.4)		.145 (3.68)		.57 (14.48)	
A 6M53M060	HTD & GT2 (3 mm)	6	6	.250 (6.35)	.370 (9.4)	.125 (3.18)	1.000 (25.4)	.50 (12.7)	1.880 (47.75)
A 6M53M090		9	9	.370 (9.4)		.145 (3.68)		.63 (16)	
A 6M55M060	HTD & GT2 (5 mm)	6	6	.250 (6.35)	.430 (10.92)	.125 (3.18)	.50 (12.7)	.50 (12.7)	.87 (22.1)
A 6M55M090		9	9	.370 (9.4)		.145 (3.68)		.63 (16)	
A 6M55M150		15	15	.605 (15.37)		.145 (3.68)		.87 (22.1)	

**NOTE:** Supplied with Hex Socket Cap Screw, Flat Washers & Elastic Stop Nut.

\*Dimensions when used with single sided belts.