

Timing Belt Clamps hold open-ended belts used in reciprocating or linear drives and provide outstanding clamping strength for the belts.

For reciprocating synchronous drives, see page **32**.

These compact, lightweight clamps made from polycarbonate resin offer a low-cost, off-the-shelf solution when space and inertia are concerns.

These patent pending clamps accommodate simple and double-sided timing belts and are supplied with stainless steel assembly hardware.

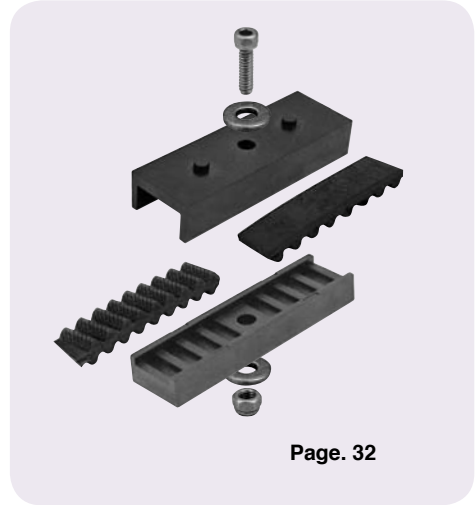

Page. 32

For linear drives, see pages **33-38**.

These clamps are made of aluminum and are available in the following pitches:

XL-1/5 inch, L-3/8 inch, HTD[®]5 & 8 mm, GT[®]2-2,3,5 & 8 mm, AT5 & 10 mm and T5 & 10 mm.

A variety of sizes are stocked to accommodate many belt widths and are supplied with all the hardware necessary for assembly.



Page. 33-38